

Flat Top Coil Conveyor Chain

This chain is used for conveying heavy weight items such as coils manufactured in hot or cold rolling processes of steel mills and steel works. We have enhanced the bearing durability and chain precision to substantially improve its functionality and extended its lifetime.

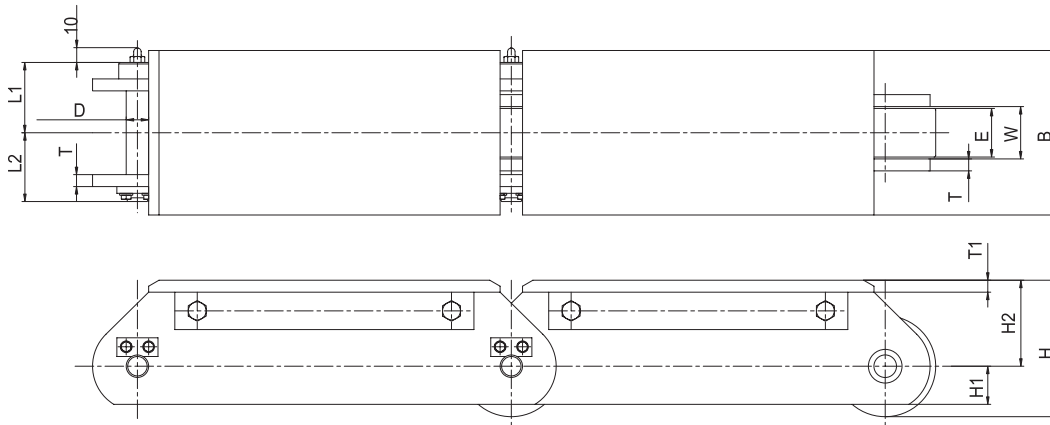
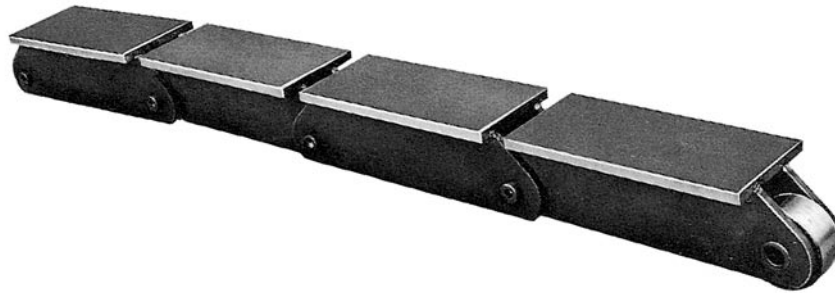

unit : mm

DONG BO CHAIN No.	Pitch P	Inner Width W	Roller			Pin		Link plate				Top plate		Approx Weight (kg/m)	load Carrying Capacity of bearing C/Co	Avg Breaking load(kgf)
			R	E	D	L ₁	L ₂	T	H	H ₁	H ₂	T ₁	B			
DBC FT60300	300													63	16,200	
DBC FT60400	400	60	125	55	28	64.5	72.5	12	154.5	45	92	12	180	58	/	60.000
DBC FT60500	500													55	13,600	
DBC FT90300	300													90	20,900	
DBC FT90400	400	62	135	55	30	74.5	81.5	16	177.5	56	110	16	190	83	/	90.000
DBC FT90500	500													79	16,800	
DBC FT90300W	300													98	24,800	
DBC FT90400W	400	78	135	71	30	82.5	89.5	16	177.5	56	110	16	210	89	/	90.000
DBC FT90500W	500													84	23,800	
DBC FT130300	300													119	28,400	
DBC FT130400	400	76	150	70	38.5	89.5	97.5	19	188	63	113	16	210	109	/	130.000
DBC FT130500	500													102	25,100	
DBC FT130600	600													97		
DBC FT160400	400													139	31,000	
DBC FT160500	500	85	175	80	41.5	95.5	102.5	19	221.5	75	134	19	220	130	/	160.000
DBC FT160600	600													122	35,000	