

Slat Chain for Automobile Assembly Line

슬래트 체인 (자동차 조립 라인용)

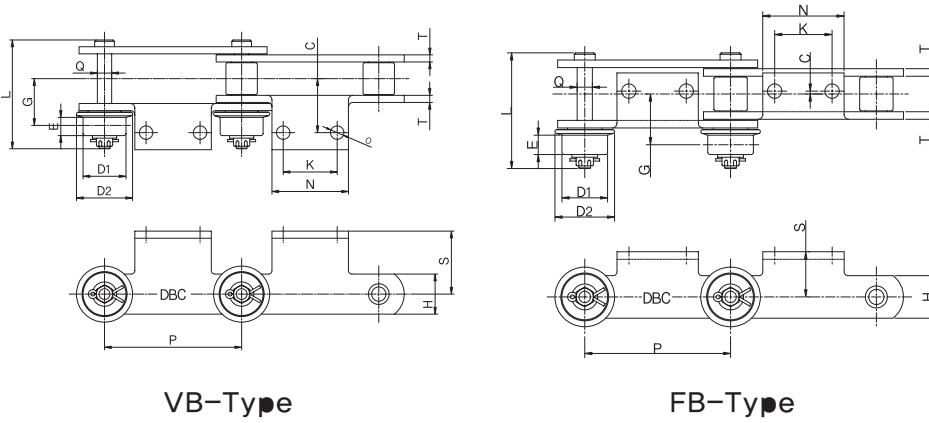

VB-Type

FB-Type

unit : mm

DONG BO CHAIN No.	Pitch P	Bearing				Link Plate		Pin		Attachment						Avg. Breaking Load (kgf)	Weight			
		D1	D2	E	G	T	H	Q	L	N	K	O	S		C		VB Type	FB Type		
DBC SL 7100	100									65	40								10.4	8.6
DBC DV 7125	125									60	40								8.7	7.6
DBC DV 7150	150									85	60								8.6	7.1
DBC DV 7200	200	45	55	16	37.5	6	32	12	96	135	80	10	70	25	50	2.5	7,800	8.3	6.6	
DBC DV 7004	101.6									67	40								10.5	8.4
DBC DV 7005	127									62	40								8.8	7.5
DBC DV 7006	152.4									87	60								8.3	6.8
DBC DV 7008	203.2									138	80								8.4	6.7
DBC DV13150	150									96	60								13.0	11.4
DBC DV13200	200									140	80								12.1	10.2
DBC DV13250	250	52	68	18	45.5	7	38	15.4	116	190	140	12	75	35	60	2.5	15,000	11.5	9.4	
DBC DV13006	152.4									98	60								12.9	11.4
DBC DV13008	203.2									143	80								12.0	10.6
DBC DV13010	254.0									194	140								11.5	9.4
DBC DV20200	200									130	80								18.6	18.3
DBC DV20250	250									180	140								18.5	16.9
DBC DV20300	300	68	84	25	56.6	9	50	21	138	230	180	12	80	45	60	2.5	24,000	17.8	16.0	
DBC DV20008	203.2									133	80								18.6	18.3
DBC DV20010	254.0									184	140								17.5	17.0
DBC DV20012	304.8									235	180								17.3	16.0

Attachment

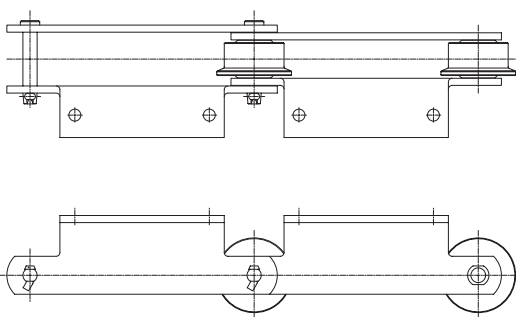

F-Type

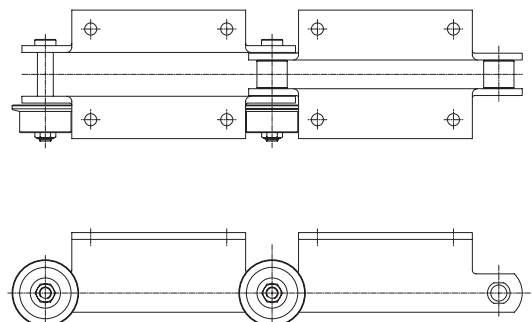

WB-Type