

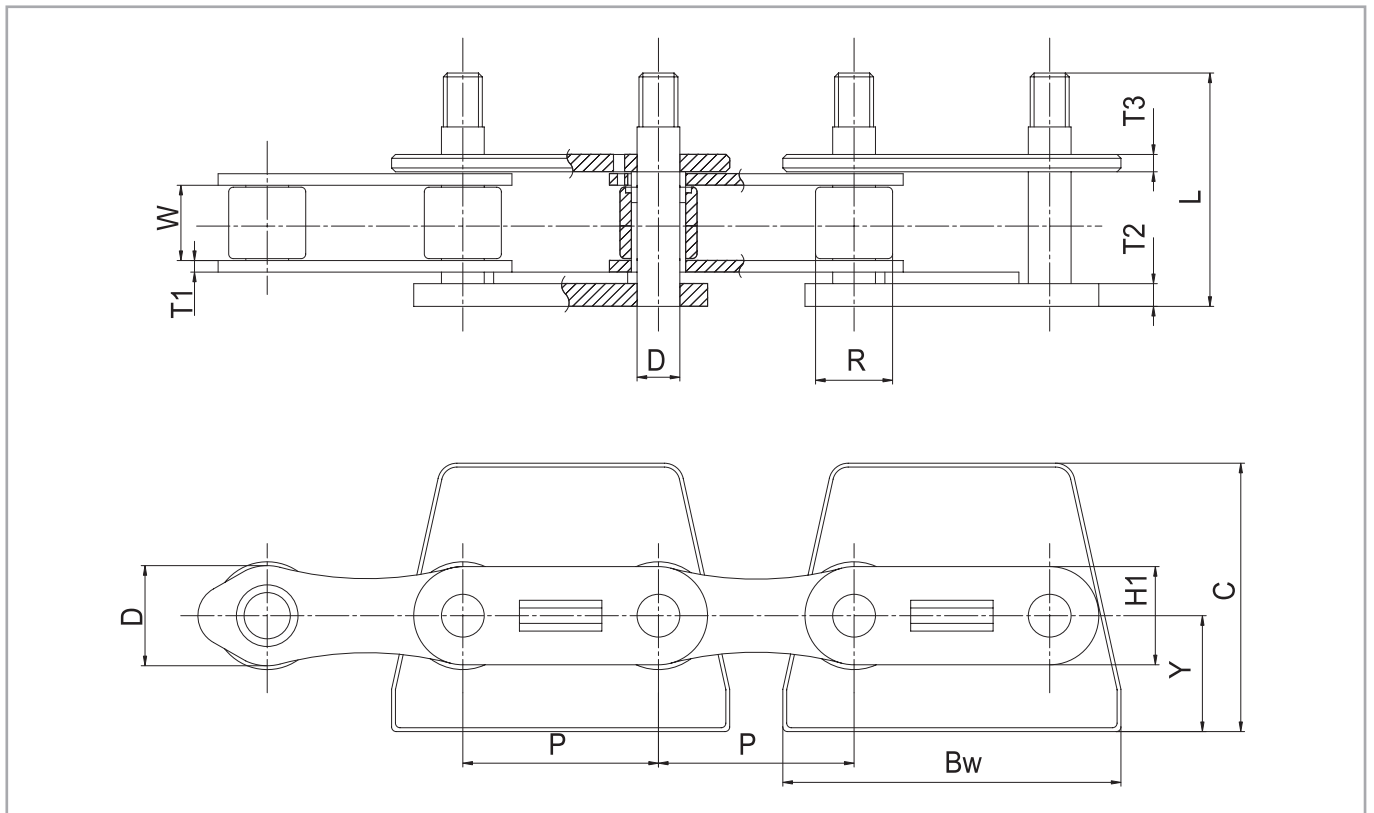

## Tenter Chain 텐타체인

Dong Bo Tenter Chain is adequate for post-dyeing, high-temperature, high-speed drying and heat processing conveyance of woven/knitted textile, non-woven fabric, carpet, and composite leather. Through hardening processing and precision engineering, it has excellent durability and fatigue resistance. In addition, the lubricating device maintains remarkable lubrication and enables high-speed, quiet operation.

동보 텐타체인은 직물, 편물, 부직포 및 카펫트, 합성피혁 등의 염색 후 고온 및 고속에 의해 건조, 혹은 열처리를 위한 이송작업에 적합한 체인입니다. 경화처리와 정밀가공으로 내마모성과 내구성 이 매우 우수함은 물론 탁월한 윤활상태의 유지를 위한 주유장치는 고속 정속운전을 가 능토록 합니다.

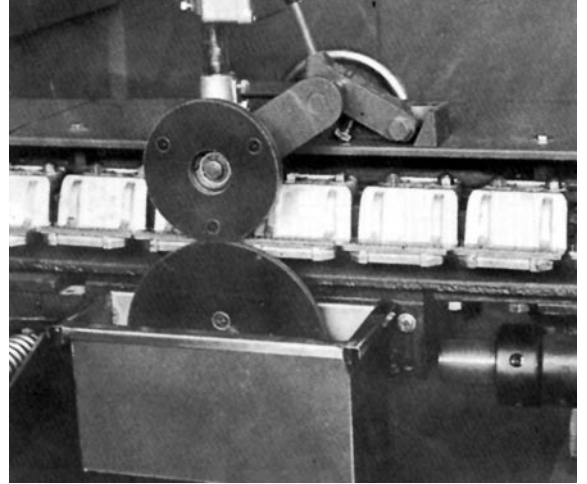

unit : mm

DONG BO CHAIN NO.	Pitch P	Roller Dia R	Inner Width W	Plate					Attachment			Pin	
				T1	T2	T3	H	H1	C	Y	Bw	D	L
<b>DBC TENTER-CH</b>	50.8	28.6	21.2	3.2	5.9	4.5	26.0	25.5	69.7	30.1	87.8	11.11	56.5